

■ **FEATURES**

- High radiant flux density
- Low coherency

■ **APPLICATIONS**

- Optical measurement
- Imaging instruments for medical



■ **ABSOLUTE MAXIMUM RATINGS (T_{op(C)} = 25 °C)**

Parameter	Symbol	Value	Unit
Radiant output power	Φ_e	35	mW
Forward current	I_f	140	mA
Reverse voltage	V_r	1.5	V
Operating temperature	$T_{op(C)}$	0 to +50	°C
Storage temperature	T_{stg}	-20 to +80	°C

■ **ELECTRICAL AND OPTICAL CHARACTERISTICS (T_{op(C)} = 25 °C)**

Parameter	Symbol	Conditions	Value			Unit
			Min.	Typ.	Max.	
Peak emission wavelength	λ_c	$\Phi_e = 30 \text{ mW}$	855	875	895	nm
Spectral radiation half bandwidth	$\Delta\lambda$		7	10	13	nm
Forward voltage	V_{op}		—	1.7	1.9	V
Forward current	I_{op}		—	110	125	mA
Beam spread angle	Parallel	$\Phi_e = 30 \text{ mW}$ FWHM	6	11	16	° (degree)
	Vertical		θ_{\perp}	26	36	46
Emitting width	—	Value at designing	—	5	—	μm
Coherent length	L_c	$\Phi_e = 30 \text{ mW}$	—	70	—	μm

SLD (Super Luminescent Diode) L11607-04

Figure 1: Radiant output power vs. Forward current (typ.)

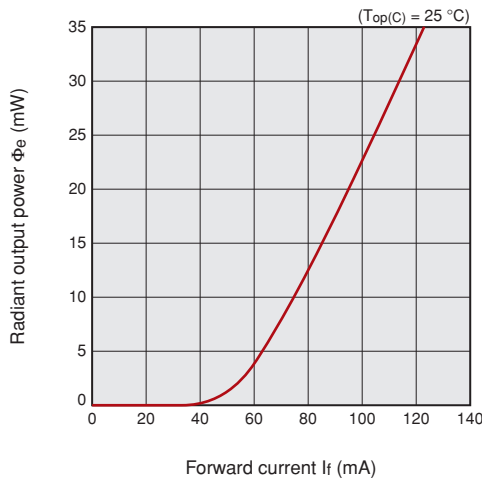

Figure 2: Typical emission spectrum

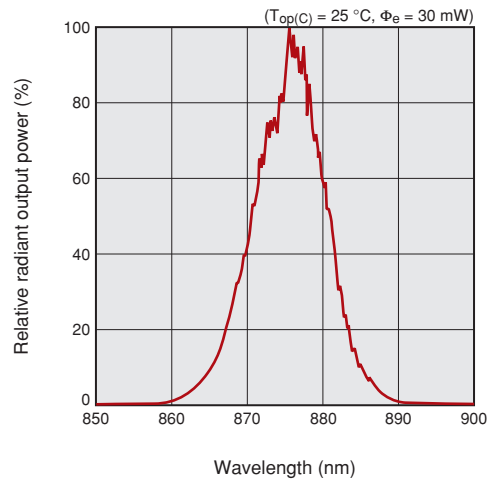

Figure 3: Directivity (typ.)

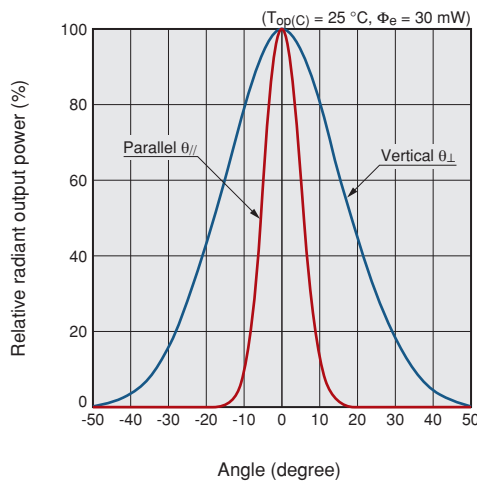
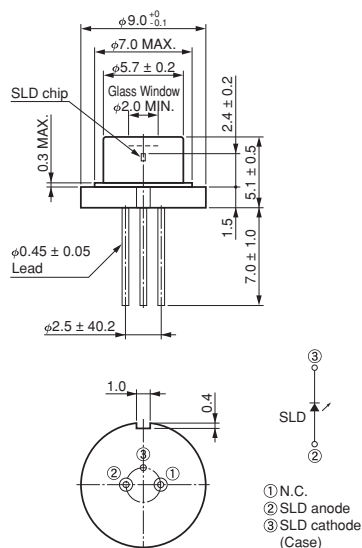

Figure 4: Dimensional outline (unit: mm)



● Information described in this material current as of October 2023. Specifications are subject to change without notice.

HAMAMATSU PHOTONICS K.K. www.hamamatsu.com

HAMAMATSU PHOTONICS K.K., Solid State Division

1126-1 Ichino-cho, Higashi-ku, Hamamatsu City, 435-8558 Japan, Telephone: (81)53-434-3311, Fax: (81)53-434-5184

U.S.A.: HAMAMATSU CORPORATION: 360 Foothill Road, Bridgewater, NJ 08807, U.S.A., Telephone: (1)908-231-0960, Fax: (1)908-231-1218 E-mail: usa@hamamatsu.com

Germany: HAMAMATSU PHOTONICS DEUTSCHLAND GMBH.: Arzbergerstr. 10, 82211 Herrsching am Ammersee, Germany, Telephone: (49)8152-375-0, Fax: (49)8152-265-8 E-mail: info@hamamatsu.de

France: HAMAMATSU PHOTONICS FRANCE S.A.R.L.: 19 Rue du Saule Trapu, Parc du Moulin de Massy, 91882 Massy Cedex, France, Telephone: (33)1 69 53 71 00, Fax: (33)1 69 53 71 10 E-mail: infos@hamamatsu.fr

United Kingdom: HAMAMATSU PHOTONICS UK LIMITED: 2 Howard Court, 10 Tewin Road, Welwyn Garden City, Hertfordshire, AL7 1BW, UK, Telephone: (44)1707-294888, Fax: (44)1707-325777 E-mail: info@hamamatsu.co.uk

North Europe: HAMAMATSU PHOTONICS NORDEN AB: Torshamnsgatan 35, 16440 Kista, Sweden, Telephone: (46)8-509-031-00, Fax: (46)8-509-031-01 E-mail: info@hamamatsu.se

Italy: HAMAMATSU PHOTONICS ITALIA S.R.L.: Strada della Moia, 1 int. 6 20044 Arese (Milano), Italy, Telephone: (39)02-93 58 17 33, Fax: (39)02-93 58 17 41 E-mail: info@hamamatsu.it

China: HAMAMATSU PHOTONICS (CHINA) CO., LTD.: 1201, Tower B, Jiaming Center, 27 Dongsanhuan Beilu, Chaoyang District, 100020 Beijing, P.R. China, Telephone: (86)10-6586-6006, Fax: (86)10-6586-2866 E-mail: hpc@hamamatsu.com.cn

Taiwan: HAMAMATSU PHOTONICS TAIWAN CO., LTD.: 13F-1, No.101, Section 2, Gongdao 5th Road, East Dist., Hsinchu City, 300046, Taiwan (R.O.C) Telephone: (886)3-659-0080, Fax: (886)3-659-0081 E-mail: info@hamamatsu.com.tw